

CONTAINERWAGEN | SGMMNS(S) 47' + VTG MODUFLAT FLEX 47'

CONTAINER CARRIER | SGMMNS(S) 47' + VTG MODUFLAT FLEX 47'



Technische Daten | technical details

■ Eigengewicht Tare weight	Ca. 18 t Approx. 18 t	■ Min. befahrbarer Kurvenradius Min. curve-radius	120 m (im Zugverband) 120 m (in block train)
■ Max. Zuladung Max. load	72 t	■ Max. Geschwindigkeit Max. speed	120 km/h
■ Radsatzlast Axle load	22,5 t 22.5 t	■ Ladelänge Loading length	14.400 mm 14,400 mm
■ Raddurchmesser Wheel diameter	920 mm	■ Ladelänge in Fuß Loading length in feet	47 ft
■ Länge über Puffer, gesamt Total length over buffers	15.640 mm 15,640 mm	■ Ladebreite Loading width	2.600 mm 2,600 mm
■ Abstand äußere Radsätze Clearance: outer wheelsets	12.000 mm 12,000 mm	■ Ladehöhe über SOK, unbeladen Loading height above top of rail, unloaded	1.155 mm
■ Bremse Brake	Ch-GP-A 16"	■ Fährbootfähigkeit Ferry boat capability	2° 30'
■ Sohlenkategorie Brake block category	LL-/K-Sohle LL/composite brake block		

Technische Daten | technical details VTG ModuFlat Flex 47'

■ Eigengewicht Tare weight	Ca. 2,9 t Approx. 2.9 t
■ Fußbodentyp Floor type	Holz Wood
■ Länge Length	14.080 mm 14,080 mm
■ Breite Width	2.764 mm 2,764 mm
■ Höhe Height	600 mm

Die VTG ModuFlat Flex 47' ist eine universell einsetzbare modulare Lösung von VTG und eignet sich z.B. für den Transport von Produkten für die Stahlindustrie wie schweren Stahlerzeugnissen und Fertigbauteilen.

The VTG ModuFlat Flex 47' is a universally suitable modular solution from VTG for transporting products for the steel industry such as heavy steel products and prefabricated components.

Wagen für den kombinierten Verkehr mit einem maximalen Ladegewicht von 72 t. Optimierte für 20'-Tank- und -Schüttgutcontainer, schwere 40'- und 45'-Container sowie auch schwere Wechselbehälter bis 7,15 m Länge.

Railcar for combined transport with a maximum loading weight of 72 t. Optimized for 20' tank and bulk containers, heavy 40' and 45' containers as well as heavy swap bodies up to 7.15 m length.

VTG GmbH
Nagelsweg 34
20097 Hamburg
Germany

Telefon +49 40 2354-0
info@vtg.com
www.vtg.com

CONTAINERWAGEN | SGMMNS(S) 47' + VTG MODUFLAT FLEX 47'

CONTAINER CARRIER | SGMMNS(S) 47' + VTG MODUFLAT FLEX 47'

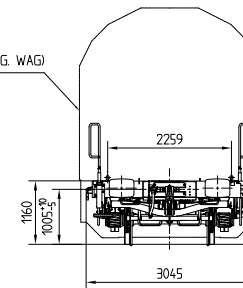
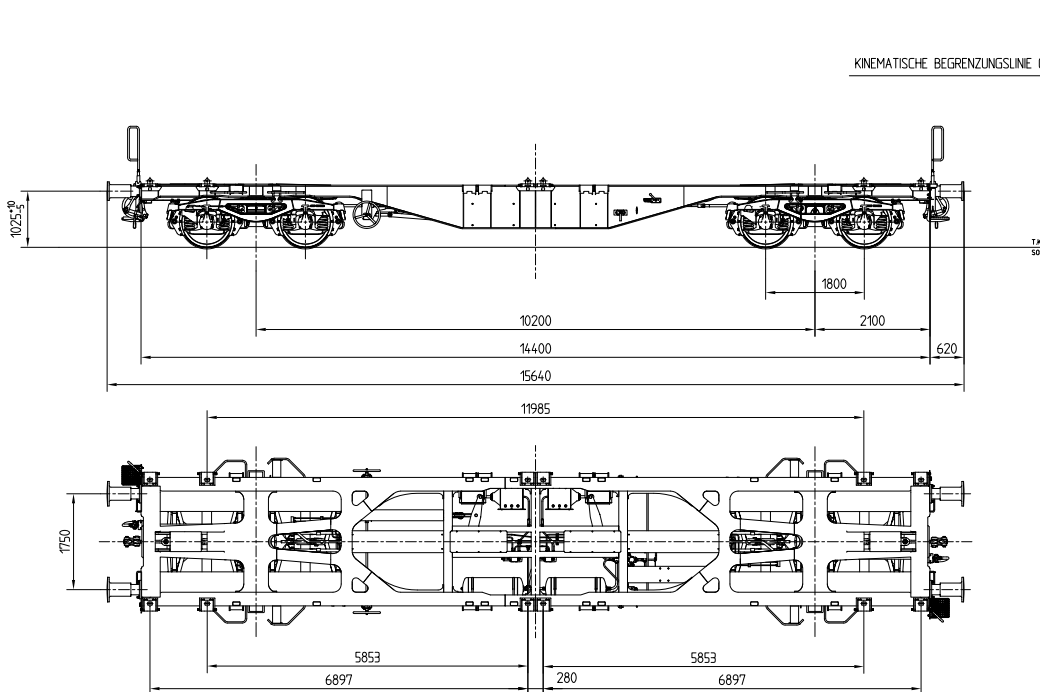

		Sgmmns			
		A	B	C	D
S	46,0	54,0	64,0	72,0	
120			00,0		

		Sgmmns			
		A	B	C	D
S	46,0	54,0	64,0	72,0	
SS	46,0	54,0	62,0		

