

CONTAINERWAGEN | SGMMNS(S) 40' + VTG MODUPALLET COILS & STEEL 40'

CONTAINER CARRIER | SGMMNS(S) 40' + VTG ModuPallet Coils & Steel 40'



Technische Daten | technical details

■ Eigengewicht Tare weight	Ca. 17,5 t Approx. 17.5 t
■ Max. Zuladung Max. load	72,5 t 72.5 t
■ Radsatzlast Axle load	22,5 t 22.5 t
■ Raddurchmesser Wheel diameter	920 mm
■ Länge über Puffer, gesamt Total length over buffers	13.610 mm 13,610 mm
■ Abstand äußere Radsätze Clearance: outer wheelsets	9.870 mm 9,870 mm
■ Bremse Brake	KE-GP-A 16" / Ch-GP-A-16"
■ Sohlenkategorie Brake block category	GG-/LL-Sohle Gray cast iron/ LL brake block

■ Min. befahrbarer Kurvenradius Min. curve-radius	120 m (im Zugverband) 120 m (in block train)
■ Max. Geschwindigkeit Max. speed	120 km/h
■ Ladelänge Loading length	12.370 mm 12,370 mm
■ Ladelänge in Fuß Loading length in feet	40 ft
■ Ladebreite Loading width	2.600 mm 2,600 mm
■ Ladehöhe über SOK, unbeladen Loading height above top of rail, unloaded	1.155 mm
■ Fährbootfähigkeit Ferry boat capability	1° 30'

Technische Daten | technical details VTG ModuPallet Coils & Steel 40'

■ Eigengewicht je Palette Tare Weight per Pallet	Ca. 8 t Approx. 8 t
■ Ladebreite (Steel) Loading width (steel)	2.300 mm 2,300 mm
■ Ladelänge (Steel) Loading length (steel)	3.000 mm – 12.500 mm 3,000 mm – 12,500 mm
■ Min. Durchmesser (Coil) Min. diameter (coil)	800 mm
■ Max. Durchmesser (Coil) Max. diameter (coil)	2.510 mm 2,510 mm
■ Max. Ladetemperatur (Coil) Max. Loading temperature (Coil)	+350°

Die Kompatibilität der VTG ModuPallet Coils & Steel 40' mit gängigen Intermodalwagen von VTG kann individuell geprüft werden.

The Compatibility of the VTG ModuPallet Coils & Steel 40' with VTG intermodal wagons, can be examined upon request.

Wagen für den kombinierten Verkehr mit einem maximalen Ladegewicht von 72,5 t. Optimierte für 20' Tank- und Schüttgutcontainer oder schwere 40' Container.

Wagon for combined transport with a maximum loading weight of 72.5 t. Optimized for 20' tank and bulk-containers or heavy 40' containers.

VTG GmbH
Nagelsweg 34
20097 Hamburg
Germany

Telefon +49 40 2354-0
info@vtg.com
www.vtg.com

CONTAINERWAGEN | SGMMNS(S) 40' + VTG MODUPALLET COILS & STEEL 40'

CONTAINER CARRIER | SGMMNS(S) 40' + VTG ModuPallet COILS & STEEL 40'

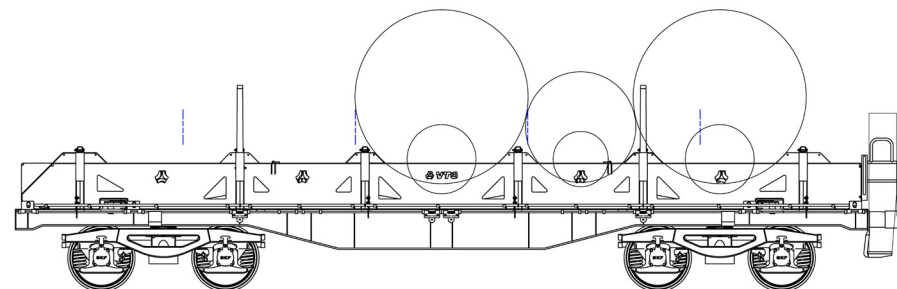
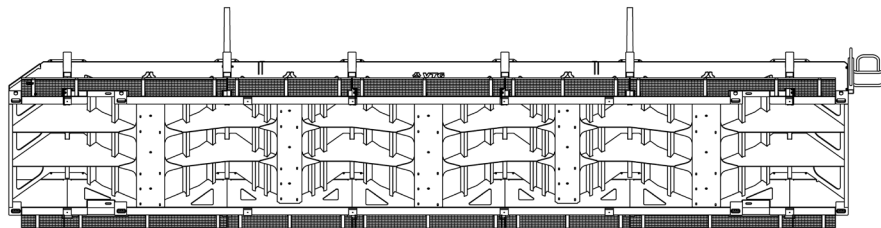
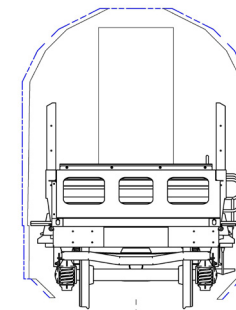
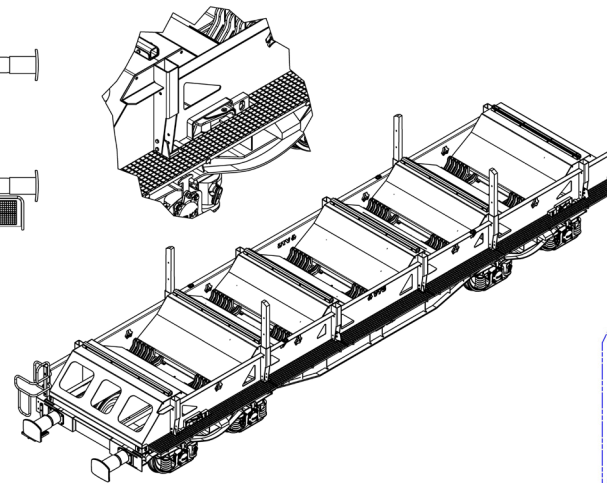
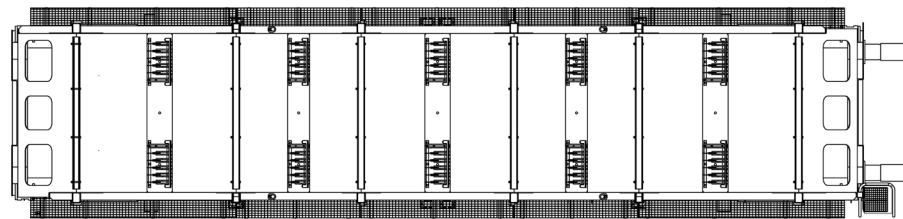

SS-Verkehr:

	A	B ₁	B ₂	C	D ₂	D ₃ D ₄
S	46,5 t	50,5 t	54,5 t	64,5 t	69,5 t	72,5 t
SS	46,5 t	50,5 t	54,5 t	62,5 t		

Lastgrenzen
Load limits
Charges limites

S-Verkehr:

	A	B ₁	B ₂	C	D ₂	D ₃ D ₄	(**)
S	46,5 t	50,5 t	54,5 t	64,5 t	69,5 t	72,5 t	
120	00,0 t						