

# MODULARER GÜTERWAGEN | SGGRRS 2x40' + VTG ModuBox BULK

## MODULAR FREIGHT CAR | SGGRRS 2x40' + VTG ModuBox BULK



### Technische Daten | technical details System

■ <b>Eigengewicht</b> Tare weight	40,9 t 40.9 t	■ <b>Min. befahrbarer Kurvenradius</b> Min. curve-radius	75 m
■ <b>Max. Zuladung</b> Max. load	139,1 t (180,0 t) 139.1 t (180.0 t)	■ <b>Max. Geschwindigkeit</b> Max. speed	100 km/h
■ <b>Radsatzlast</b> Axle load	22,5 t 22.5 t	■ <b>Ladelänge</b> Loading length	2 x 12.370 mm 2 x 12,370 mm
■ <b>Raddurchmesser</b> Wheel diameter	920 mm	■ <b>Ladelänge in Fuß</b> Loading length in feet	2 x 40' (ft)
■ <b>Länge über Puffer, gesamt</b> Total length over buffers	max. 26.710 mm max. 26,710 mm	■ <b>Ladehöhe über SOK, unbeladen</b> Loading height above, top of rail, unloaded	1.155 mm 1,155 mm
■ <b>Abstand äußere Radsätze</b> Clearance: outer wheelsets	22.880 mm 22,880 mm	■ <b>Fährbootfähigkeit</b> Ferry boat capability	Nein No
■ <b>Bremse</b> Brake	KE-GP-A		
■ <b>Sohlenkategorie</b> Brake block category	K		

### Technische Daten | technical details ModuBox Bulk

■ <b>Eigengewicht</b> Tare weight	2,950 t 2.950 t
■ <b>Max. Bruttogewicht</b> Max. gross weight	38,0 t 38.0 t
■ <b>Volumen</b> Volume	46,0 m <sup>3</sup> 46.0 m <sup>3</sup>
■ <b>Ladelänge</b> Loading length	20'
■ <b>Ladebreite</b> Loading width	max. 2.900 mm max. 2,900 mm
■ <b>Ladehöhe</b> Loading height	2.900 mm 2,900 mm

Die ModuBox Bulk ist aufgrund ihrer standardisierten Bauform kompatibel mit gängigen Intermodal-Wagen der VTG. Spezielle System-Lösungen können von der VTG geprüft werden.

The ModuBox Bulk is due to its standardized construction, compatible with VTGs common intermodal fleet. Specific system solutions can be examined upon request.



Der Sgrrs 2x40' ermöglicht es, mit seinem optimierten Eigengewicht mehr Zuladung je Wagen zu realisieren.

Die ModuBox Bulk, die modulare Lösung der VTG für den Transport von leichten (Bsp.: Hackschnitzel) und mittelschweren Schüttgütern (Bsp.: Koks, Kohle), bis zu einem spezifischen Eigengewicht von 1t/m<sup>3</sup> passt perfekt dazu.

Das volumenoptimierte Design in Verbindung mit dem geringen Gewicht des Wagens ermöglicht eine signifikante Steigerung der Zuladung je Wagen.“

The ModuBox Bulk is VTGs modular solution for the transport of light bulk (e.g.: woodchips), as well as medium weight bulk (e.g.: coke and coal) materials, with a density of up to 1 ton per m<sup>3</sup>.

The volume optimised box design, in combination to the light wagon design, allows for a significant increase in loaded product per wagon.

VTG Rail Europe GmbH  
Nagelsweg 34  
20097 Hamburg  
Germany

Phone +49 40 2354-0  
info@vtg.com  
www.vtg.com

# MODULARER GÜTERWAGEN | SGGRRS 2x40' + VTG ModuBox BULK

## MODULAR FREIGHT CAR | SGGRRS 2x40' + VTG ModuBox BULK

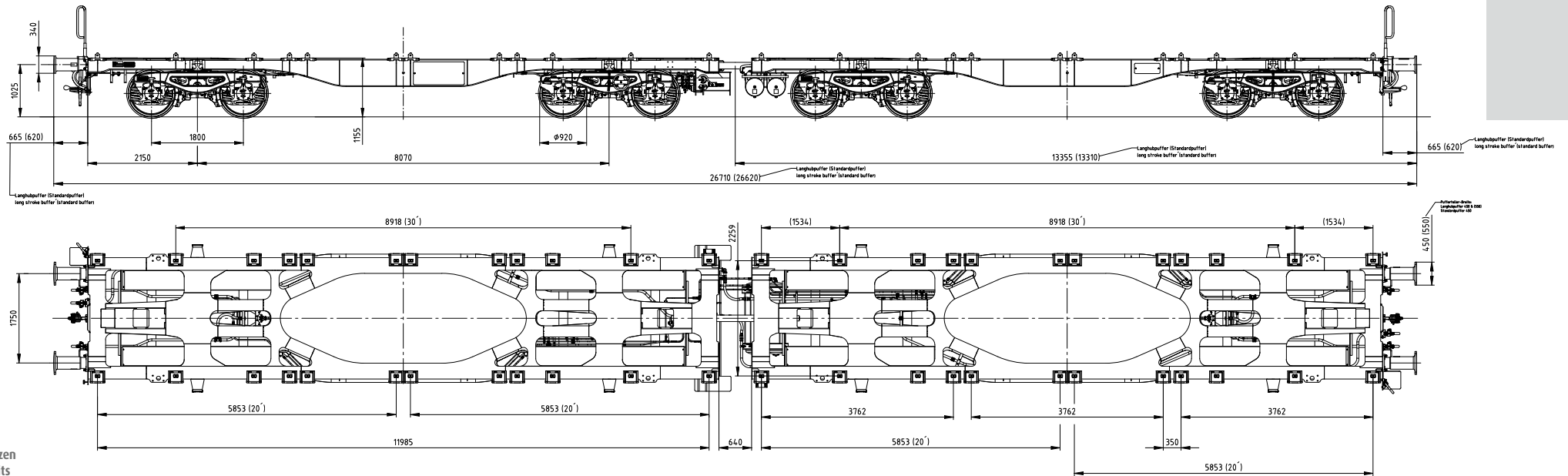

Lastgrenzen  
Load limits

	A	B1	B2	C2	C3	C4	D2	D3	D4
S	87,1	92,6	103,1		123,1		130	139,1	

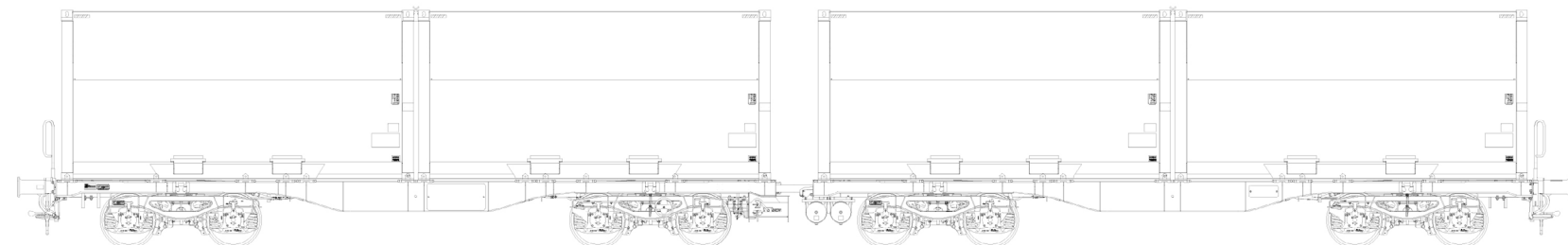

VTG Rail Europe GmbH  
Nagelsweg 34  
20097 Hamburg  
Germany

Phone +49 40 2354-0  
info@vtg.com  
www.vtg.com

# MODULARER GÜTERWAGEN | SGGRRS 2x40' + VTG ModuBox BULK

## MODULAR FREIGHT CAR | SGGRRS 2x40' + VTG ModuBox BULK

