

VAGÓN AUTOPISTA FERROVIARIA | POCKET WAGON

Sdggmrss – T4000



Datos técnicos | technical details

■ Tara Tare weight	37,0 t 37,0 t				
■ Carga neta máxima Max. load	98 t 98 t				
■ Carga máx.bruta por eje Axle load	22,5 t 22.5 t				
■ Diámetro de rueda Wheel diameter	920 mm				
■ Distancia entre topes Total length over buffers	34.200 mm 34,200 mm				
■ Distancia entre pivotes Bogie Distance between Bogie Pivots	2 x 14.200 mm 2 x 14,200 mm				
■ Distancia entre ejes extremos Clearance: Outer wheelsets	30.200 mm 30,200 mm				
■ Freno Brake	KE-GP-A				
■ Tipo de zapata Brake block category	Zapata K K brake block				
■ Ancho de vía Track Gauge	1.435 mm / 1.668 mm 1,435 mm / 1,668 mm				
■ Altura de enganche de semirremolque Heights of Trailer Hitch	880 mm / 980 mm / 1.130 mm 880 mm / 980 mm / 1,130 mm				
		■ Min. Radio de giro Min. drivable turning radius		En tren: 150 m Como un solo vagón: 120m (Ancho de vía 1.668 mm) 75 m (Ancho de vía 1.435 mm) In block train: 150 m as single wagon: 120 m (track gauge 1,668 mm) 150 m (track gauge 1,435 mm)	
		■ Velocidad máxima Max. speed		120 km/h	
		■ Longitud de Carga Loading length		Max. 2 x 15.761 mm resp. 4 x 7.820 mm - Cajas móviles (C782) Max. 2 x 15,761 mm or 4 x 7,820 mm - swap bodies (C782)	
		■ Longitud carga en pies Loading length in feet		104 ft	
		■ Altura sobre el carril, vagón vacío Loading height above top of rail, unloaded		270 mm para semirremolque 1.155 mm para cajas móviles y contenedores 270 mm for trailer 1,155 mm for swap bodies and containers	
		■ Ancho del vagón Pocket width		2.700 mm 2,700 mm	
		■ Ancho de carga Loading width		2.600 mm para contenedores 2,600 mm for Container	
		■ Adecuado para ferries Ferry boat capability		1° 30' , R = 120 m	

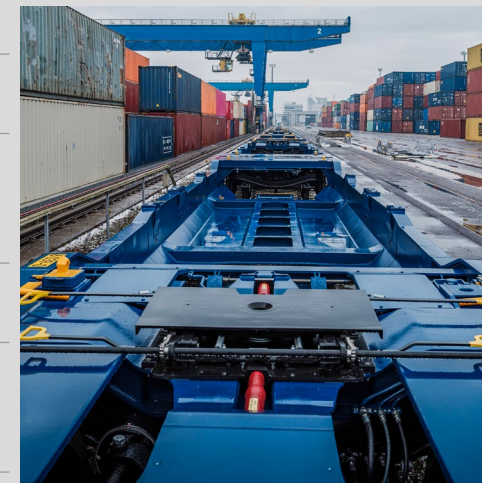

Este vagón pocket de autopista ferroviaria multifuncional está diseñado para operar en la Península Ibérica (ES, PT). Con un ancho de 2.700 mm y sus generosas dimensiones, el vagón es adecuado para el transporte de (Mega-) Remolques de hasta 15.100 mm de longitud.

Un soporte del enganche del semirremolque ajustable en altura permite una carga y descarga eficientes. El vagón puede equiparse con cestas r2l para el transporte de semirremolques no elevables con grúa.

This multifunctional double pocket wagon is designed for operation on the Iberian Peninsula (ES, PT). With a 2,700 mm wide pocket and its generous dimensions the wagon is suitable for the transport of (Mega-)Trailers up to 15,100 mm length. A height-adjustable trailer hitch ensures an efficient loading and unloading operation.

The wagon can be equipped with r2l baskets for transport of non-cranable trailers.

VTG GmbH
Nagelsweg 34
20097 Hamburg
Germany

Tel: +49 40 2354-0
info@vtg.com
www.vtg.com

VAGÓN AUTOPISTA FERROVIARIA | POCKET WAGON



Sdggmrss – T4000

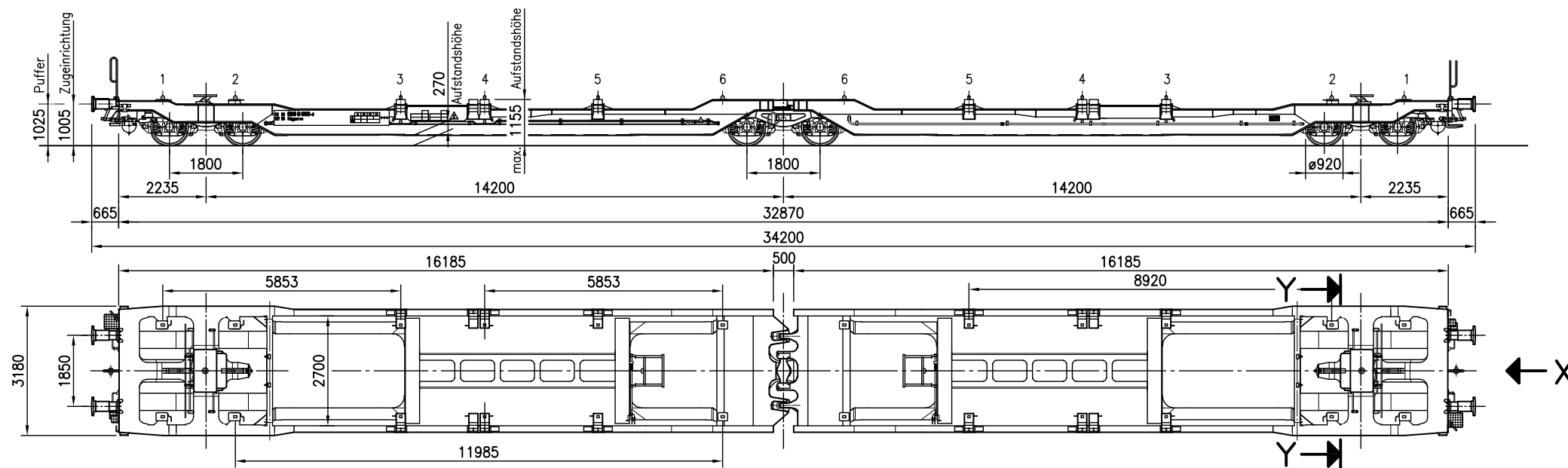

VTG GmbH
Nagelsweg 34
20097 Hamburg
Germany

Tel: +49 40 2354-0
info@vtg.com
www.vtg.com